

Europäisches Patentamt  
European Patent Office  
Office européen des brevets



(11) **EP 0 987 925 A1**

(12) **EUROPEAN PATENT APPLICATION**

(43) Date of publication:  
**22.03.2000 Bulletin 2000/12**

(51) Int. Cl.<sup>7</sup>: **H05B 33/02, H05B 33/04**

(21) Application number: **98117604.3**

(22) Date of filing: **16.09.1998**

(84) Designated Contracting States:  
**AT BE CH CY DE DK ES FI FR GB GR IE IT LI LU  
MC NL PT SE**  
Designated Extension States:  
**AL LT LV MK RO SI**

(72) Inventor: **Aoki, Shigehiko**  
**Sumida-ku, Tokyo (JP)**

(71) Applicant: **SEIKO PRECISION INC.**  
**Tokyo (JP)**

(74) Representative:  
**Grünecker, Kinkeldey,  
Stockmair & Schwanhäusser  
Anwaltssozietät  
Maximilianstrasse 58  
80538 München (DE)**

(54) **EL light emission device**

(57) An EL light emission device includes an expanded plastic layer (6,7) provided on at least one of front and rear surfaces of an EL panel (E), as a damping means to absorb vibration. The expanded plastic layer has bubbles existing therein, and absorbs vibration propagating to a communication means of a handy telephone, thus serving to suppress against noise occurrence.

*FIG. 1*

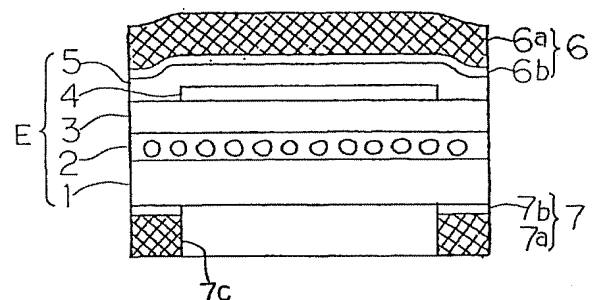

**EP 0 987 925 A1**

## Description

### BACKGROUND OF THE INVENTION

#### 1. Field of the invention

[0001] This invention relates to EL light emission devices for use in backlights and the like.

#### 2. Description of the prior art

[0002] Liquid crystal displays are utilized as display means for electronic appliances, such as handy telephones, various remote control units, small-sized instruments and so on. In some of the above-mentioned appliances, devising has been made such that the operating panel when used in a dark is illuminated in order to facilitate button operations. These liquid crystal displays and operating panels have backlight sources generally employing an LED, a fluorescent tube lamp, or the like. Such backlights are provided with a light scattering plate for scattering the light being transmitted there-through, as a means for uniformly brighten a display surface at the front of the liquid crystal display or the operating panel.

[0003] Meanwhile, the recent advancement in the field of electronic appliances, particularly handy telephones, is prominent, which in turn requires more strongly the need for reduction in size and thickness. Consequently, liquid crystal displays and operating panels has been reduced in thickness. There is also requirement for the backlights used therefor to be compatible with such thickness reduction. However, the appliances employing an LED or fluorescent tube as a backlight, as stated in the prior art, essentially require the provision of both a light source and a light scattering plate, thus limiting to the reduction in thickness thereof.

[0004] For this reason, there is a tendency toward adopting EL panels as backlights for handy-telephone displays or operating portions. However, the EL panel generates vibration due to application of a.c. voltage during light emission, and there is a problem that such vibration causes noise to occur in the handy telephone or the like. That is, the vibration occurring from the EL panel propagates to a communication means of the handy telephone, thus causing noise during communication and hence hindering comfort talking.

### SUMMARY OF THE INVENTION

[0005] It is therefore an object of the present invention to provide an EL light emission device which can prevent vibration from occurring during light emission by an EL panel thereof.

[0006] An EL light emission device according to the present invention, is characterized by providing an expanded plastic layer on at least one of front and rear surfaces of an EL panel, as a damping means to absorb

vibration. The expanded plastic layer has bubbles existing therein, and absorbs vibration propagating to a communication means of a handy telephone, thus serving to suppress against noise occurrence.

5 [0007] The expanded plastic layer can employ a foaming adhesive tape. However, the expanded plastic layer is formed by applying an expandable ink with using a printing plate and baking the ink, it is possible to enhance producibility. Also, if the expandable ink comprising a screen-printing ink added with a foaming agent by 3 - 30 wt% is employed so that the ink is applied by screen printing and baked, the thickness of the EL panel can be controlled by adjusting an adding amount of the foaming agent besides the enhancement in operationality. This can cope with the limitation in installation space for the EL panel.

### BRIEF DESCRIPTION OF THE DRAWINGS

20 [0008]

Fig. 1 is a sectional view of a principal part of an EL light emission device according to a first embodiment of the present invention; and

25 Fig. 2 is a sectional view of a principal part of an EL light emission device according to second and third embodiments of the present invention.

### DETAILED DESCRIPTION OF THE INVENTION

30 [0009] Referring to Fig. 1, there is illustrated a principal part of an EL light emission device according to a first embodiment of the present invention. In the figure, reference characters 1 - 5 denote constituent elements of an EL panel E. The EL panel E has, on opposite surfaces, foaming adhesive tapes 6, 7 as expanded plastic layers characterized by the present invention.

[0010] Now an EL emission body E will be explained. The EL emission body E has a transparent conductive film 1 provided at a front (at an underside in Fig. 1) and formed of a transparent polyester film or the like sputtered with an ITO thin film.

[0011] The transparent conductive film 1 also has a luminous layer 2 formed on a backside thereof. The luminous layer 2 is formed by screen-print applying and curing a fluorescent article, such as zinc sulfide (ZnS), kneaded with a high dielectric binder. An insulating layer 3, provided on the backside of the luminous layer 2, is formed by screen-printing and curing a paste of barium titanate (BaTiO<sub>3</sub>) or the like kneaded with a high dielectric binder.

[0012] The insulating layer 3 has a rear electrode 4 formed on a backside thereof. The rear electrode 4 is formed only at an area as a light emission surface. The rear electrode 4 is provided by printing and curing using a conductive paste containing a carbon powder kneaded with a binder.

[0013] A rear cover layer 5 is formed covering over the

rear electrode 4 and the insulating layer 3 at other than an area having the rear electrode. The rear cover layer 5 is formed by printing and curing polyester-based resist.

**[0014]** On the backside of the rear cover layer 5, an expanded plastic layer 6 is formed. The expanded plastic layer 6 is formed by a foaming adhesive tape 6a having a adhesive layer 6b and put over an entire backside surface. The foaming adhesive tape 6a employs as an example SFO330HM (commodity name, by Dainippon Ink and Chemicals Inc.). This foaming adhesive tape has a roughened surface formed due to foaming. Consequently, where the EL panel is mounted within a case of a handy phone in a manner contact therewith, the presence of the foaming adhesive layer 6 absorbs vibration generated by the EL panel and prevents it from propagating to the case and other call means of the handy hone.

**[0015]** The foaming adhesive tape 6a is put, during a manufacturing process, to the entire back surface of a multiplicity of the EL light emission bodies continuously arranged in a matrix form having rows and columns, prior to separating them into individual ones. When separating the EL light emission bodies, the foaming adhesive tape 6a is divided and separated, together and simultaneously with the EL light emission bodies, into individual ones.

**[0016]** Another expanded plastic layer 7 is also provided on a front surface of the transparent conductive film 1, which is formed of the same material as the above-stated foaming adhesive tape. The front-side expanded plastic layer 7 is formed at an area except for an area 7c serving as a display portion. The expanded plastic layer 7, formed by a foaming adhesive tape 7a and an adhesive 7b, is previously put on the front surface, excepting the area 7c for a display portion, of the EL panel. The expanded plastic layer 7 is cut and separated together simultaneously with separating the EL panels.

**[0017]** Now a second embodiment of an EL light emission device will be explained with reference to Fig. 2. Fig. 2 shows a sectional structure of the second embodiment, wherein an EL light emitting body E denoted by reference characters 1 - 5 is structured same as that of the first embodiment.

**[0018]** As illustratively shown, the rear cover layer 5 has an expanded plastic layer 8 on a back surface thereof, while the transparent conductive film 1 has an expanded plastic layer 9 on a front surface thereof. The area where the respective expanded plastic layers 8, 9 are provided is also similar to that of the first embodiment.

**[0019]** The expanded plastic layers 8, 9 is formed by applying an expandable ink through a printing plate and then baking it. The expandable ink employs as an example a REFOAM S (commodity name, by Toyo Ink Manufacturing Co., Ltd.). This expandable ink is printed only over a desired (or required) area by using a patterned

printing plate, and baked at a temperature of 110°C thereby forming expanded plastic layers 8, 9.

**[0020]** The formation of the expanded plastic layers 8, 9 with using an expandable ink requires only processes of printing and baking, providing an advantage of reducing manufacturing cost. In connection to this, the process including the putting on a foaming adhesive tape as in the first embodiment involves also the operation of cutting an adhesive layer. This may lead to adhesion of the adhesive onto a cutter during cutting and hence troublesome encountered in cutting operation. Thus, such a process may be worse in operationality than the present embodiment.

**[0021]** Now a third embodiment of an EL light emission device will be explained. This embodiment has a structure similar in general appearance to that of the second embodiment, and explanations are made with reference to Fig. 2.

**[0022]** This embodiment employs an expandable ink made of a usual screen-printing ink added with a foaming agent. The foaming agent may be, for example, an SV foaming agent (commodity name, by Nagase Screen Printing Laboratory). This foaming agent is added by 3 - 30 wt% to a screen-printing ink to prepare an expandable ink. The expandable ink is applied by screen printing to over a desired area of an EL light emission body and similarly baked at a temperature of 110°C, thus forming expanded plastic layers 8, 9. The thickness of the expanded plastic layer can be controlled by adjusting the adding amount of the foaming agent. This process therefore suited for a case where there exists limitation in thickness of an EL light emission device. Incidentally, if the adding amount of the foaming agent is 3 wt% or less, expanding phenomenon will not occur and the agent does not serve as a damping material. On the other hand, if 30 wt% or greater, peeling of the resulting layer off an underlying layer may occur. Thus, the adding amount is desirably 3 - 30 wt%.

**[0023]** In the third embodiment, if a transparent screen-printing ink is used, it is possible to make an expandable ink nearly transparent. Where using such a transparent expandable ink, the expandable ink may be provided over the entire front surface of the transparent conductive film 1. In such a case, the expandable ink on the panel front side can serve as a light scattering plate.

**[0024]** The above-described structures of the EL light emission devices were explained as mere examples. The present invention is not limited to the thick-film EL panel, but applicable also to a thin-film organic EL panel. Also, the above embodiments were provided with expanded plastic layers on the respective surfaces of the EL panel. However, the expanded plastic layer may be provided on any one of the surfaces, due to considerations such as the thickness and so on.

**[0025]** According to the present invention, an expanded plastic layer is provided as a damping material on at least one of respective surfaces of an EL panel. Consequently, the vibration occurring from the

EL panel is absorbed by this. No vibration propagates to a case or communicating means of a handy telephone provided with this. Thus, noise is prevented from occurring.

**[0026]** Also, if the expanded plastic layer is provided by applying and baking an expandable ink, the expanded plastic layer is easy to form, thus achieving cost reduction. 5

**[0027]** Further, if the expandable ink employs a screen-printing ink added with a foaming agent by a predetermined ratio, the thickness of the expanded plastic layer can be controlled by adjusting an adding amount of the foaming agent. This provides an expanded plastic layer that can cope with a case that there is a limitation in the thickness of the EL light emission device. 10 15

**Claims**

- 1. An EL light emission device, characterized by providing an expanded plastic layer on an EL panel to absorb vibration caused during emission of light by said EL panel. 20
- 2. An EL light emission device according to claim 1, wherein said expanded plastic layer is formed of an expandable ink by printing. 25
- 3. An EL light emission device according to claim 2, wherein said expandable ink comprises a screen-printing ink added with a foaming agent by 3 - 30 wt%. 30

35

40

45

50

55

FIG. 1

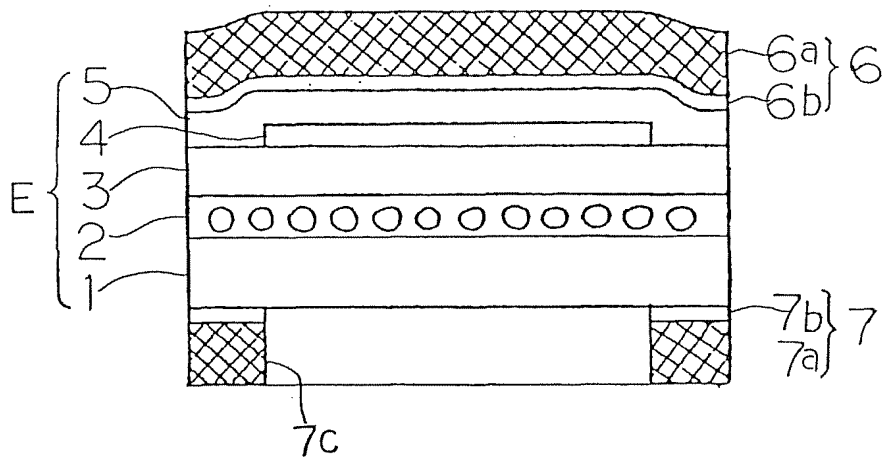
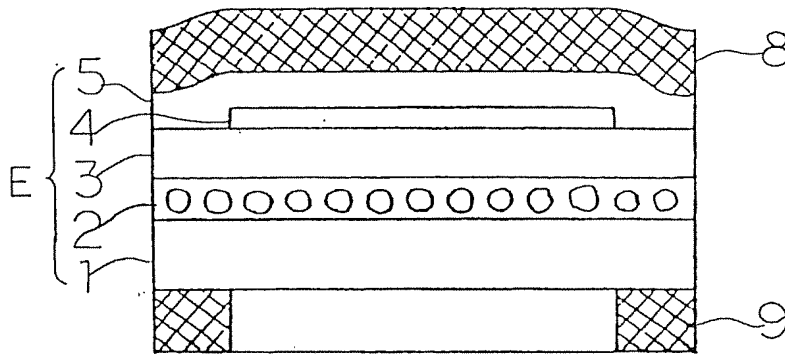

FIG. 2





European Patent  
Office

EUROPEAN SEARCH REPORT

Application Number  
EP 98 11 7604

DOCUMENTS CONSIDERED TO BE RELEVANT			
Category	Citation of document with indication, where appropriate, of relevant passages	Relevant to claim	CLASSIFICATION OF THE APPLICATION (Int.Cl.6)
E	DATABASE WPI Section EI, Week 9902 Derwent Publications Ltd., London, GB; Class U14, AN 99-015438 XP002091505 & JP 10 284247 A (SEIKO PRECISION KK) , 23 October 1998 * abstract *	1	H05B33/02 H05B33/04
X	----- PATENT ABSTRACTS OF JAPAN vol. 098, no. 013, 30 November 1998 & JP 10 228979 A (YAMAGATA CASIO CO LTD), 25 August 1998 * abstract *	1-3	
X	----- PATENT ABSTRACTS OF JAPAN vol. 098, no. 013, 30 November 1998 & JP 10 215085 A (CASIO COMPUT CO LTD); 11 August 1998 * abstract *	1	
X	----- PATENT ABSTRACTS OF JAPAN vol. 004, no. 005 (E-165), 16 January 1980 & JP 54 146593 A (SHARP CORP), 15 November 1979 * abstract *	1	TECHNICAL FIELDS SEARCHED (Int.Cl.6) H05B
The present search report has been drawn up for all claims			
Place of search <b>THE HAGUE</b>		Date of completion of the search <b>28 January 1999</b>	Examiner <b>Drouot, M-C</b>
<b>CATEGORY OF CITED DOCUMENTS</b> X : particularly relevant if taken alone Y : particularly relevant if combined with another document of the same category A : technological background O : non-written disclosure P : intermediate document		T : theory or principle underlying the invention E : earlier patent document, but published on, or after the filing date D : document cited in the application L : document cited for other reasons ..... & : member of the same patent family, corresponding document	

EPO FORM 1503 03/82 (P04/C01)